

Omron's First Complete System for Sensing Under Vacuum

- Vacuum rated to 1×10^{-10} Pa • m³/s max. (7.5×10^{-10} torr • l/s)
- The industry's First *4-Channel Snap-On Fiber Mounting Feature* allows ease of use and implementation
- A Single-Channel Flange with screw-mounting is also available
- Increases process productivity by performing operations inside vacuum chambers
- The external fiber can be cut on both ends, allowing customized lengths
- Stainless steel and fluoro-resin fiber cables are available for vacuum processes
- CE approval



Ordering Information

■ CONFIGURATION EXAMPLE (TYPICAL)

To Order a Complete Fiber-Optic System for Sensing Under Vacuum

Select:

- A Flange
- Vacuum Fibers
- External Fiber Cable
- A Lens Unit (if necessary)
- The Appropriate Fiber-Optic Amplifier

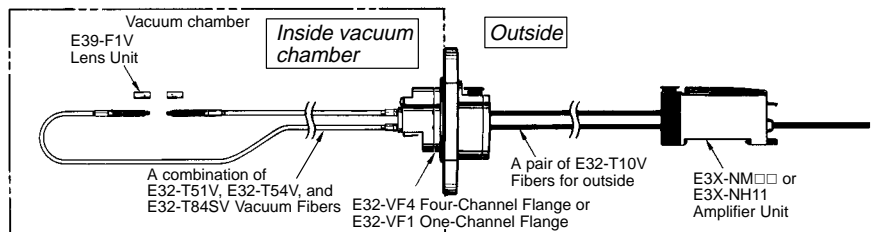

■ FLANGES

Item	Part number
Four channel	E32-VF4
One-channel	E32-VF1

■ VACUUM FIBERS

Item	Through-beam, straight model	Through-beam, 90° model	Through-beam, heat-resistant model
Part number	E32-T51V 1M	E32-T54V 1M	E32-T84SV 1M
	E32-T51V 0.5M	E32-T54V 0.5M	—

■ FIBERS FOR OUTSIDE

Item	Part number
External Fiber Cable	E32-T10V 2M

■ LENS UNIT

Item	Part number
Long distance lens	E39-F1V

■ AMPLIFIER UNIT W/HIGH-PRECISION SENSING AND TEACH FUNCTION (SOLD SEPARATELY)

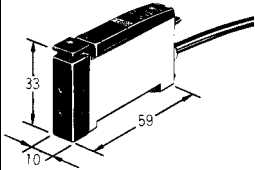
Item	NPN output	PNP output
Part number	E3X-NH11	E3X-NH41
Appearance		
Light source	Red LED ($\lambda = 680 \text{ nm}$)	
Power supply voltage	12 to 24 VDC $\pm 10\%$, ripple (p-p) 10% max.	
Current consumption	75 mA max.	
Response time	1 ms max. (see note)	
Output	Control output	NPN open collector, load current: 50 mA max., residual voltage: 1 V max.
	Alarm output	
Sensitivity setting	Teaching method	
Fine sensitivity adjustment	Automatic or manual fine threshold adjustment (13 levels)	

Note: The E3X-NH adopts a new digital sensing algorithm and has the same capacity for detecting minute objects as the conventional E3X-NT□1 (response time of 0.5 ms).

■ FOUR-CHANNEL AMPLIFIER UNIT WITH TEACH FUNCTION (SOLD SEPARATELY)

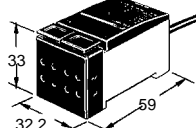
Item	Four-channel
Part number	E3X-NM11 (NPN output) E3X-NM41 (PNP output)
Appearance	
Light source	Red LED ($\lambda = 680 \text{ nm}$)
Power supply voltage	12 to 24 VDC $\pm 10\%$, ripple (p-p) 10% max.
Current consumption	150 mA max.
Response time	500 μs max. at rated sensing distance
Control output	PNP or NPN open collector, load current: 100 mA, residual voltage: 1 V max.
Timer function (see note)	OFF-delay timer (fixed to 40 ms) (independent channel)
Teaching confirmation function	Indicator (red/green LEDs) and buzzer
Remote teaching input	Pink and blue (0 V) wires are short-circuited when remote input is ON. (0 V short-circuit current: 1 mA max.) Pink and blue (0 V) wires are not short-circuited when remote input is OFF. (Open or 9 V min.; max. input voltage: 24 V) Response time is 0.5 ms max. when remote input is OFF.
Mode	Light-ON and Dark-ON switch-selectable

Note: It is possible to disable the OFF-delay timer function by using the switch setting.

■ DIGITAL FIBER AMPLIFIER UNIT (SOLD SEPARATELY)

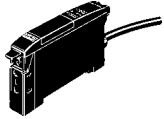
Item	NPN output		PNP output		NPN output		PNP output	
Part number	E3X-DA11		E3X-DA41		E3X-DA21		E3X-DA51	
Appearance								
Light source (wavelength)	Red LED (660 nm)							
Supply voltage	12 to 24 VDC \pm 10%, ripple (p-p) 10% max.							
Current consumption	75 mA max.							
Response time	High-speed mode: 250 μ s for operation and reset Standard mode: 1 ms for operation and reset Long-distance mode: 4 ms for operation and reset							
Control output	ON/OFF output	NPN open collector Load current: 50 mA max. Residual voltage: 1 V max.	PNP open collector Load current: 50 mA max. Residual voltage: 2 V max.	NPN open collector Load current: 50 mA max. Residual voltage: 1 V max.	PNP open collector Load current: 50 mA max. Residual voltage: 2 V max.			
	Monitor output	---			Load 1 to 5 VDC, 10 k Ω min. Load resistance 10 k Ω min.			
Sensitivity setting	Teaching or manual method							
Timer function	OFF-delay timer, range: 0 to 200 ms (5 ms increment)							

Specifications

■ RATINGS/CHARACTERISTICS

Flanges

Item	E32-VF4	E32-VF1
Number of channels	Four-channel	One-channel
Vacuum ratings	1 x 10 ⁻¹⁰ Pa • m ³ /s max. (7.5 x 10 ⁻¹⁰ torr • l/s)	
Ambient operating temperature	-25°C to 55°C (-13°F to 131°F) with no icing	
Material	Aluminum (A5056)	Stainless steel (SS 304)
Flange seal material	Fluoro rubber	
Weight	Approx. 250 g	Approx. 220 g

Fiber Unit for Outside

Item	E32-T10V	
Standard length	2 m (cut freely)	
Ambient operating temperature	-25°C to 70°C (-13°F to 158°F) with no icing	
Permissible bending radius	25 mm max.	
Material	Core	Acrylic resin
	Sheath	Fluoro-resin
	Protection tube	Black polyethylene

Vacuum Fibers

Item	E32-T51V	E32-T54V	E32-T84SV	
Sensing method	Through-beam			
Standard length	1 m (not cut freely)			
Sensing distance	E3X-NM11/NM41	60 mm	40 mm	150 mm
	E3X-NH11	100 mm	100 mm	400 mm
Ambient operating temperature	-25°C to 120°C (-13°F to 248°F) with no icing		-25°C to 200°C	
Permissible bending radius	30 mm max.		25 mm max.	
Material	Core	Quartz		Optical glass
	Sheath	Fluoro-resin		Optical glass
	Protection tube	Fluoro-resin		Stainless steel (SS 304)
	Fiber head/ Connection tube	Aluminum (A5056), Stainless steel (SS 304)		

Lens Unit

Item	E39-F1V		
Applicable fiber	E32-T51V		E32-T54V
Sensing distance	E3X-NM11/NM41	360 mm	240 mm
	E3X-NH11	700 mm	600 mm
Ambient operating temperature	-25°C to 120°C (-13°F to 248°F) with no icing		
Material	Housing	Aluminum (A5056)	
	Lens	Optical glass	

Dimensions

Unit: mm (inch)

■ FLANGES

E32-VF4

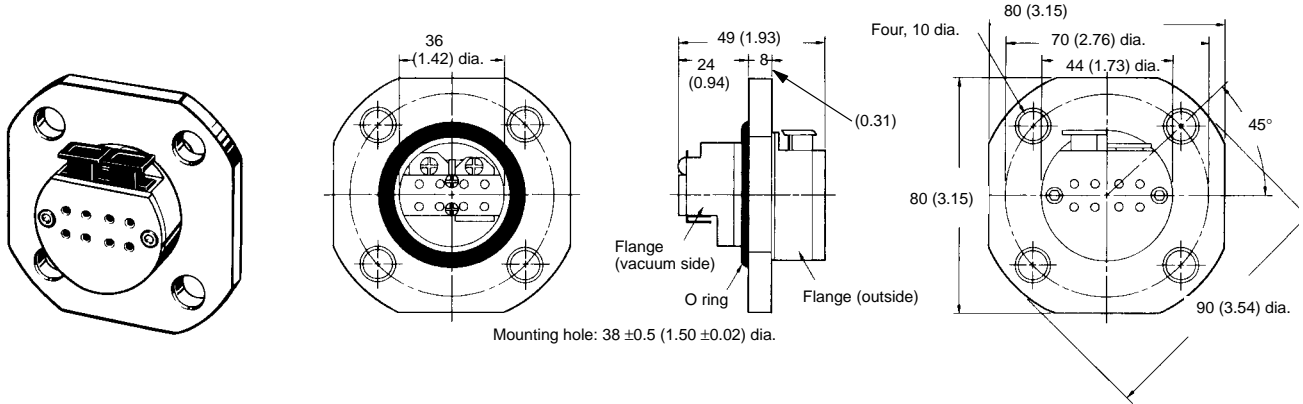

E32-VF1

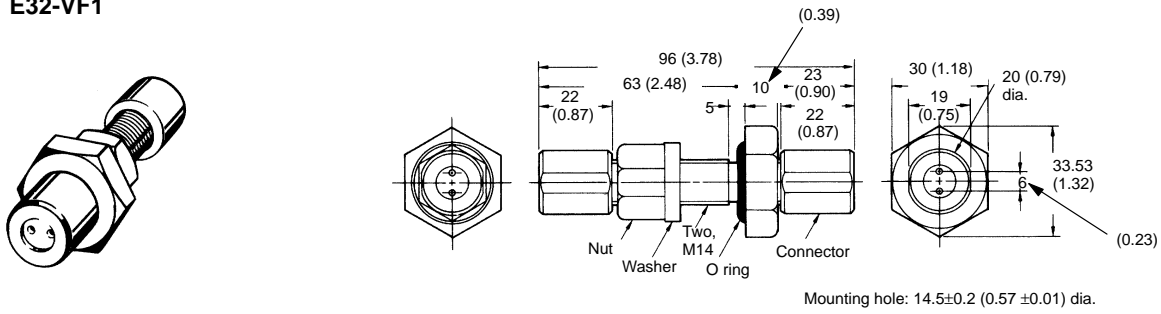

■ VACUUM FIBERS

E32-T51V

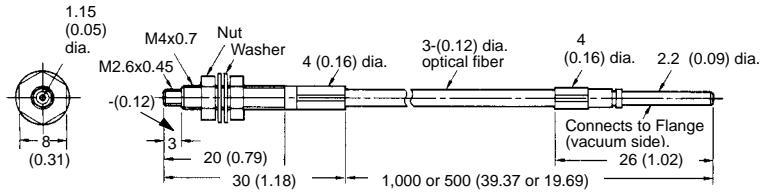
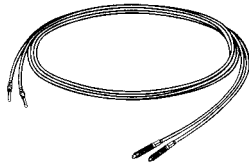

E32-T54V

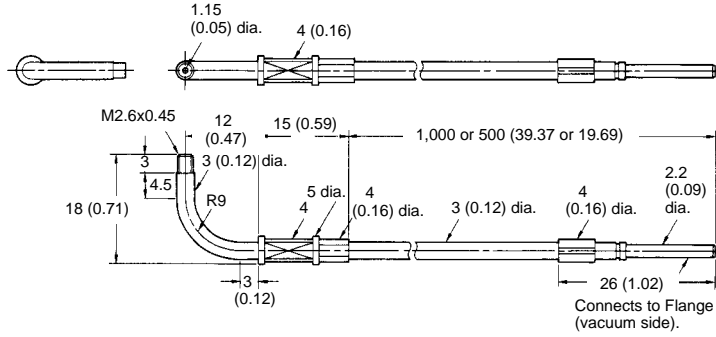
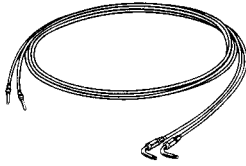

E32-T84SV

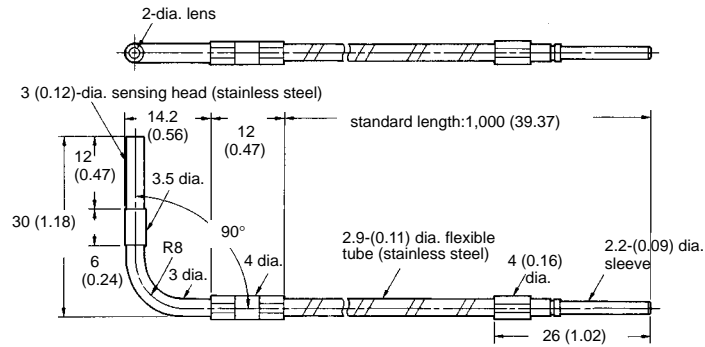
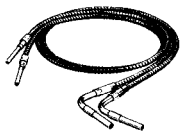

■ MOUNTING BRACKET

E39-L54V Mounting Bracket (Sold Separately)

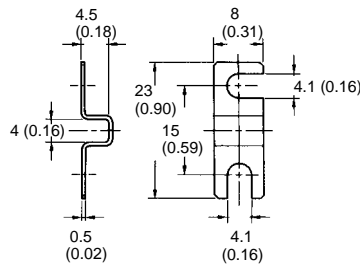

Material: SS 304

Unit: mm (inch)

■ EXTERNAL FIBER CABLE

E32-T10V

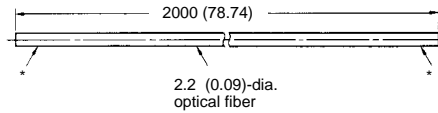
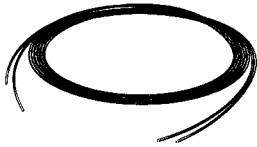

* Freely cut and connected to the outside Flange or Amplifier Unit.

■ LENS UNIT

E32-F1V

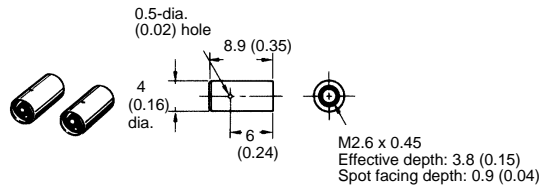

■ AMPLIFIER (SOLD SEPARATELY)

E3X-NH11

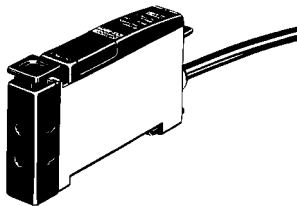

Note: The mounting bracket can be attached to side A.

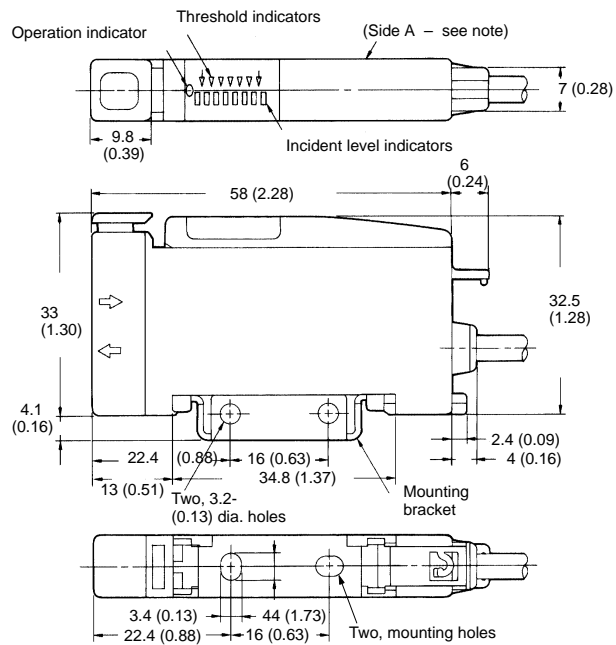
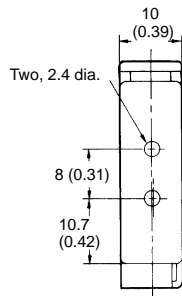

Cable: Polyvinyl chloride covered cable
 4-mm dia. (18/0.12 dia), 4 cores
 Standard length: 2 m
 Weight: Approx. 100 g

■ AMPLIFIER UNIT (SOLD SEPARATELY)

E3X-NM11
E3X-NM41

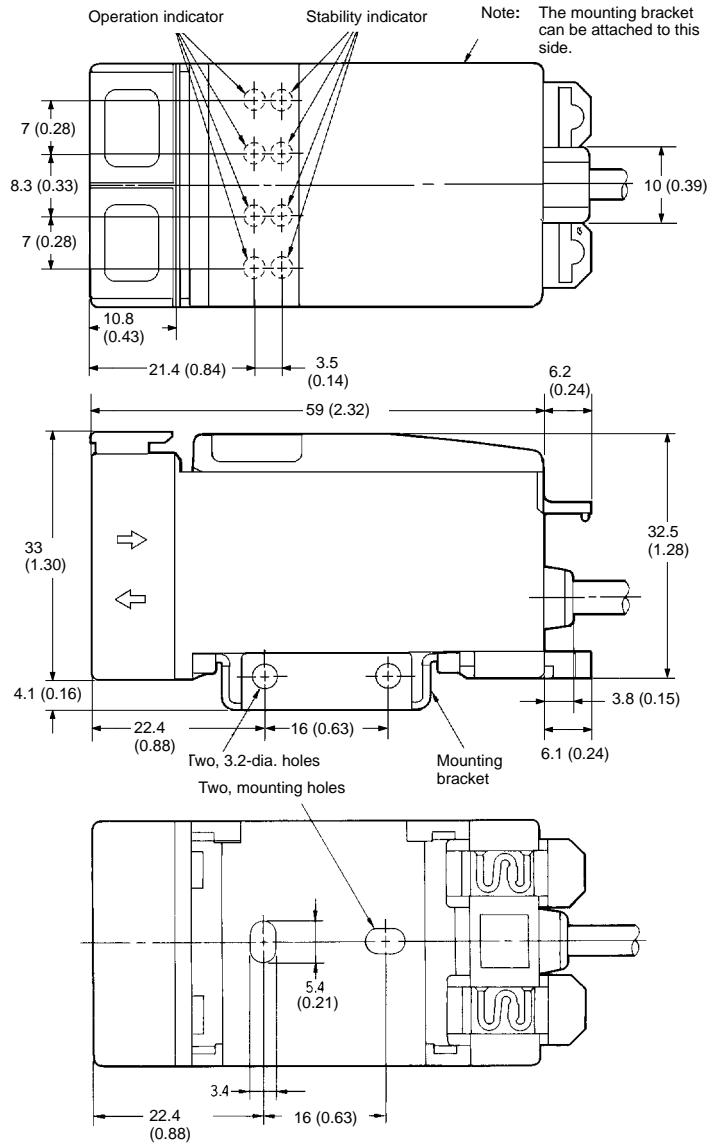
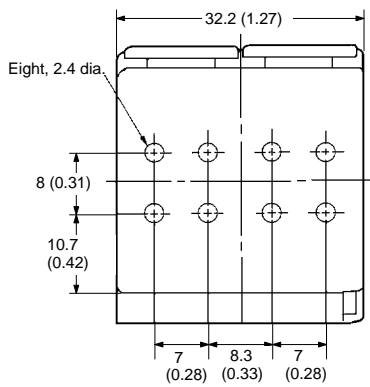
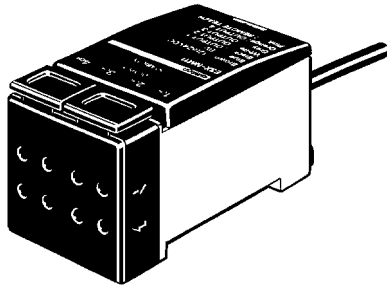

Cable: Polyvinyl chloride-covered cable
4-mm dia. (40/0.08 dia), 7 cores
Standard length: 2 m
Weight: Approx. 200 g

■ AMPLIFIER

E3X-DA□1

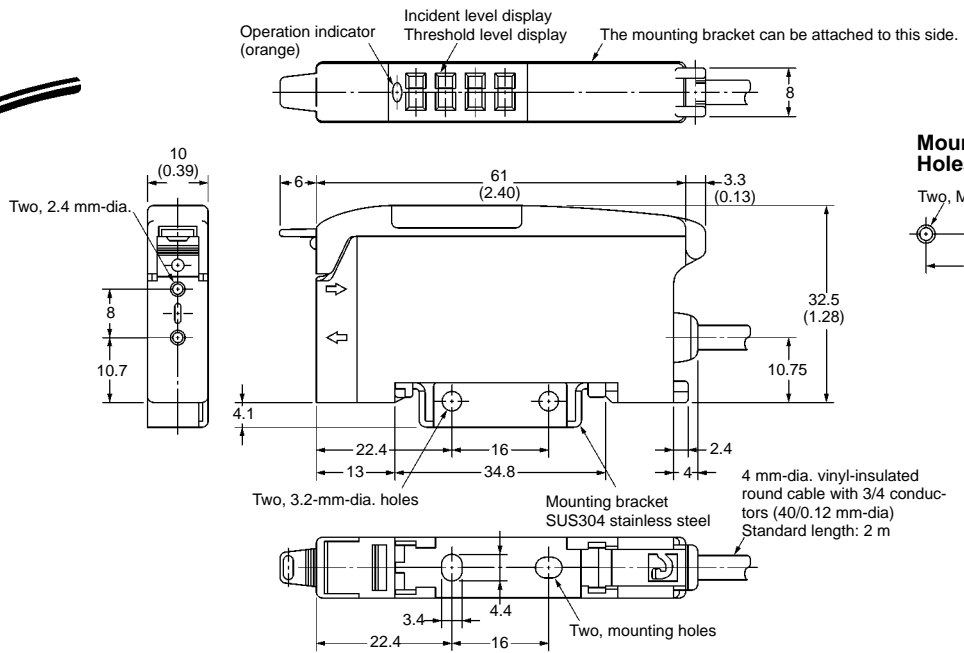
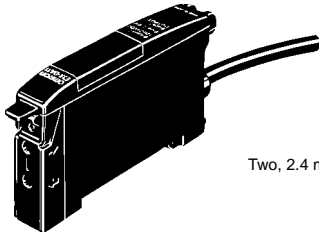

Engineering Data (with E3X-NM11/NM41 Amplifier Unit)

EXCESS GAIN RATIO VS. DISTANCE CHARACTERISTICS (TYPICAL)

E32-T51V

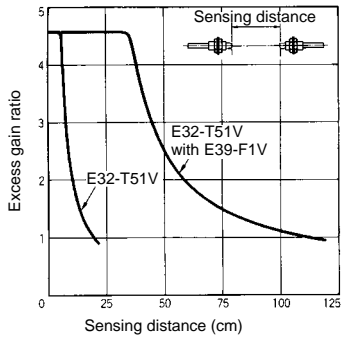

E32-T54V

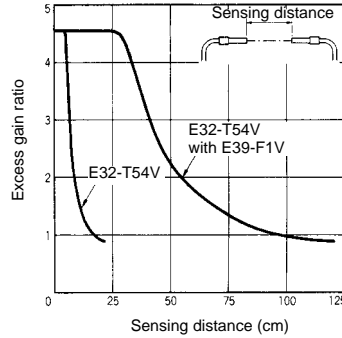

E32-T84SV

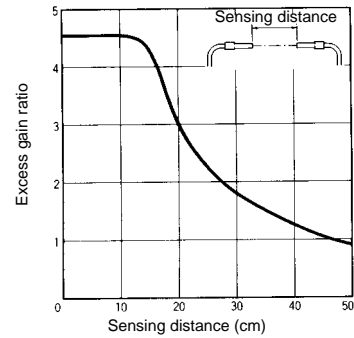

PARALLEL OPERATING RANGE (TYPICAL)

E32-T51V

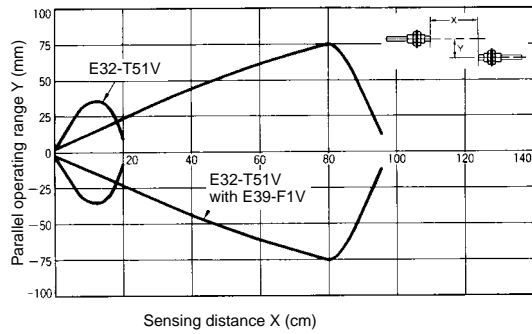

E32-T54V

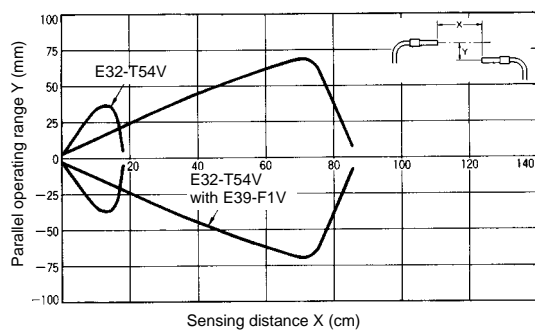

E32-T84SV

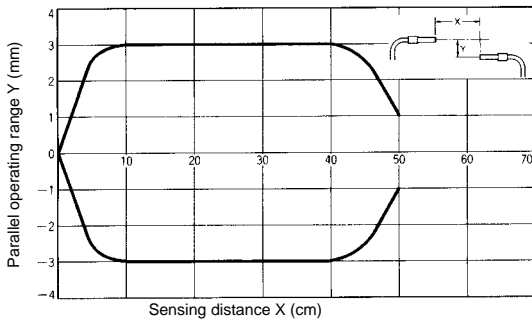

Engineering Data (with E3X-NH11 Amplifier Unit)

■ EXCESS GAIN RATIO VS. DISTANCE CHARACTERISTICS (TYPICAL)

E32-T51V

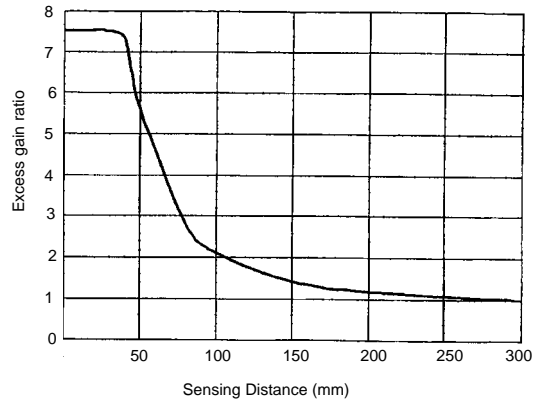

E32-T54V

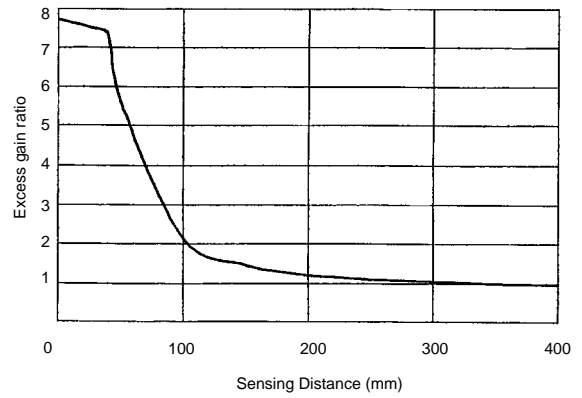

E32-T51V + E39-F1V

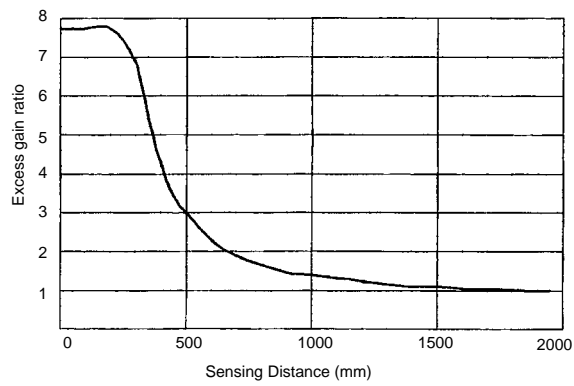

E32-T54V - E39-F1V

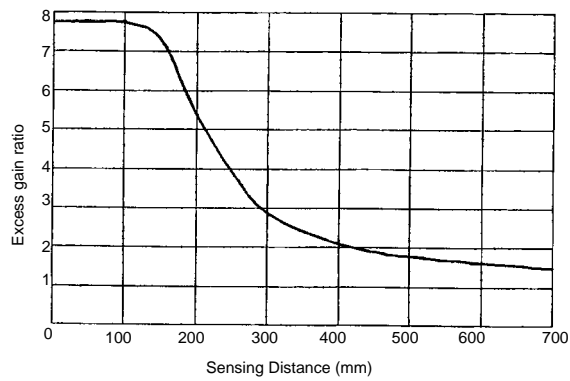
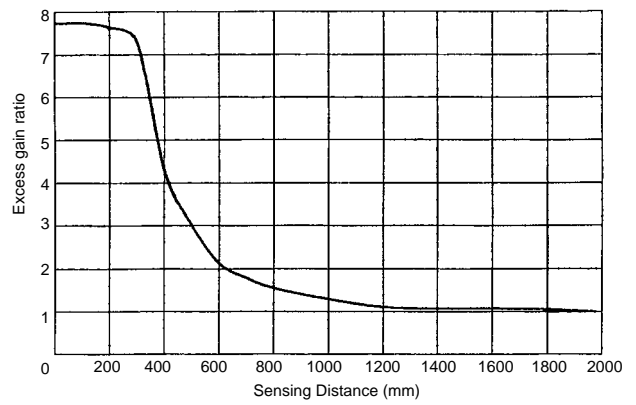

■ PARALLEL OPERATING RANGE (TYPICAL)

E32-T51V
E32-T51V + E39-F1V

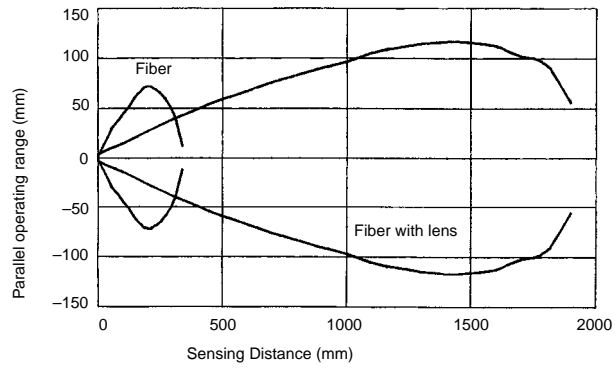

E32-T54V
E32-T54V + E39-F1V

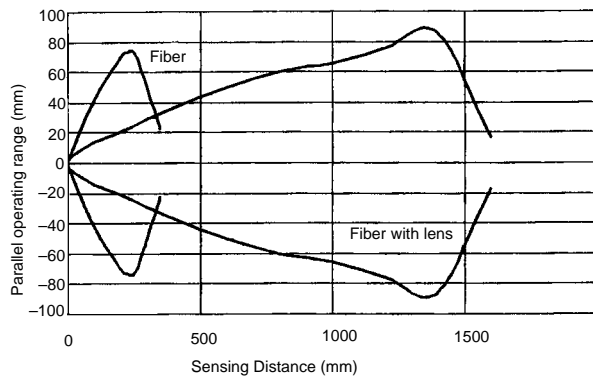

E32-T84SV

